

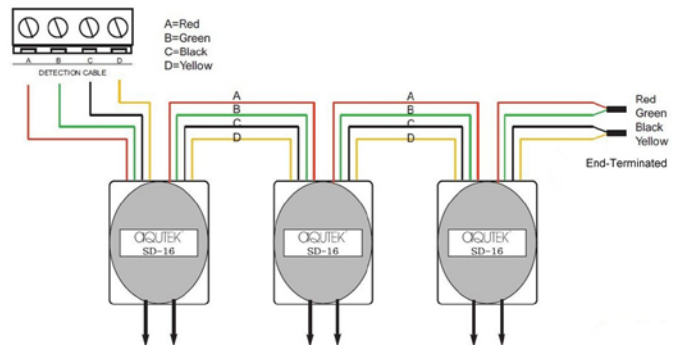

SD -16 Spot Type Water Leakage Detector

Product Description

- Compact Design and Easy To Use. Low installation cost, no need for external power supply wires or external power source.
- Robust & Waterproof. All circuitries and electronic components are embedded inside epoxy resin.
- Long Service Life, expectancy of more than 10 years.
- Practically No Maintenance is needed.
- Multiple detectors can be connected in series.



Technical Specifications

- Dimension: about 57 x 47 x 39mm (without the sensing probes)
- Weight: 50g
- Sensing Probes:
 - Package comes with a pair of "L" shape conductive electrode probes which can be setup into two different detection height levels by different orientation.
 - Can be replaced with most of the water sensing cables in the market.



Model Number: SD -16-5
Equivalent to 5m Cable Length



Model Number: SD -16-10
Equivalent to 10m Cable Length



OQUTEK[®] Asia Limited
www.Aqutek.Asia

The content of this brochure is for reference only. Aqutek Asia Limited reserves the right to make changes without notification.